

connect

4 CONNEX for transformers
and GIS substations

10 Pioneering overhead line equipment
14 HV-CONNEX fit for esters



Legal Notice

Publisher

PFISTERER Kontaktsysteme GmbH
Rosenstraße 44
73650 Winterbach
Germany
Tel: +49 7181 7005 0
Fax: +49 7181 7005 565
info@pfisterer.com
www.pfisterer.com

Editorial Team:

Reto Aeschbach, Peter Arranz
Andreas Dobler, Julia Faltin
Peter Feldhofer, Jürgen Finsinger
Matthias Freiling, Peter Kaiser
Lena Miunske, Gerhard Mühlberger
Matthias Pirch, Martin Schuster
Barbara Simeon, Christian Späth
Sergio Thaddey, Michael Zerrer

Text Editor

Karolina Kos
www.xyzeiler.de

Art Direction

VISCHER&BERNET GmbH
Marketing and Advertising Agency
Stuttgart

Cover picture

Bystrup

© Copyright by PFISTERER
Kontaktsysteme GmbH

PFISTERER Customer and Staff Magazine Issue 2 2013

- 4 CONNEX for transformers and GIS substations
- 8 Earthing terminal for cables with lead or corrugated metal sheathing
- 9 New phase comparator: SPPC 5 and SPPC 5 dual
- 10 Insulator strings for modern overhead lines
- 12 First EST installation in Austria
- 14 HV-CONNEX successfully type tested in esters
- 16 The Fundamentals of Contact Technology
- 23 News



Editorial

Expertise in action

Contacting high current conductors, insulating high voltages – our core competences have grown over the years, and are still in great demand. This issue of CONNECT will be presenting projects and products that illustrate this perfectly.

Swiss customers invariably fit their transformers and switchgear with the CONNEX system – find out why from page 4. You can learn why advanced high-voltage towers in Denmark are equipped with our composite insulator strings from page 10. The unmatched speed with which the EST can be assembled was demonstrated during its first installation in Austria – see page 12.

How our products combine experience with meeting current specifications is explained in the report on the Fundamentals of Contact Technology starting on page 16, as well as the report on the approval of HV-CONNEX in esters from page 14 onwards.

No matter where you start, we hope you find the read worthwhile. And we hope that you will be using us for your next project. We are ready for for you!

Sincerely,

Jörg Fries

CSO
PFISTERER Holding AG

CONNEX for substations: Safe and economical

„Safe, easy to install, economical.“
When asked, Roland Büttler does not take long to explain the benefits of CONNEX. The Project Manager for Primary Equipment at Alpiq AG EnerTrans should know, as he invariably uses our connector system. From cable connectors to HV surge arresters. From medium to high voltage. For connecting and protecting transformers and switchgear. How exactly this is done can be seen by visiting two substations in Switzerland.

The first stop is the Klus substation, located in the village of the same name in the canton of Solothurn. Operational since 2007, it provides security of supply to the regions of Oensingen, Balsthal, Thal und Mümliswil in north-western Switzerland. It is a joint project between power company Alpiq Versorgungs AG (AVAG), AEK Energie AG (AEK) and onyx Energie Mittelland, run by Alpiq AG EnerTrans. Energy business Alpiq has been building high-voltage networks for over 80 years and switchgear for power transmission and power distribution. The knowledge and experience of the business that had previously traded under the name Atel were brought together in January 2011 as Alpiq AG EnerTrans.



Technical discussions with experts: Roland Büttler, General Manager of the Klus Substation (left) and Reto Aeschbach, Sales Manager Switzerland at PFISTERER (right)

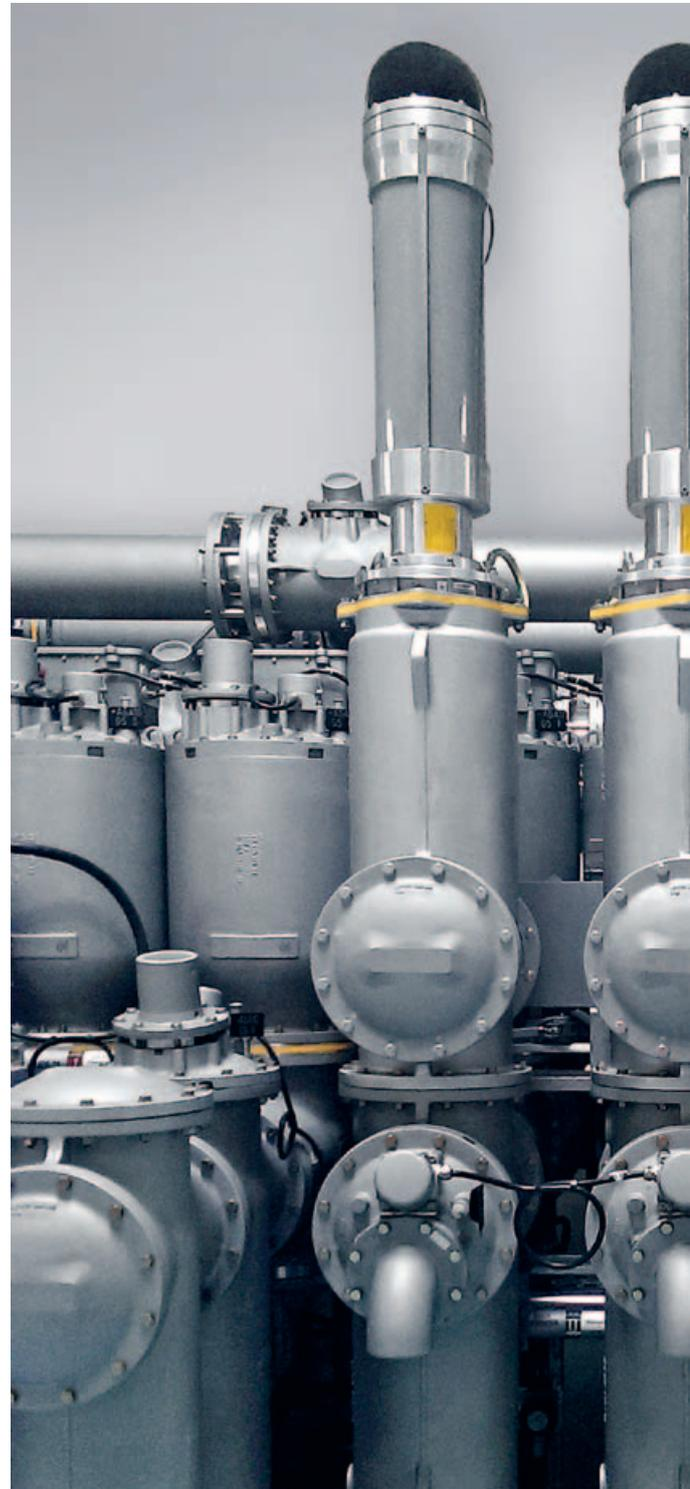

Cost-effective retrofit solution for the Niedergösgen substation: The standard termination enclosure from the GIS system manufacturer combined with HV-CONNEX socket and Size 4 HV-CONNEX surge arrester from PFISTERER for extending the single-phase switchgear and the switchgear for power transmission and distribution.

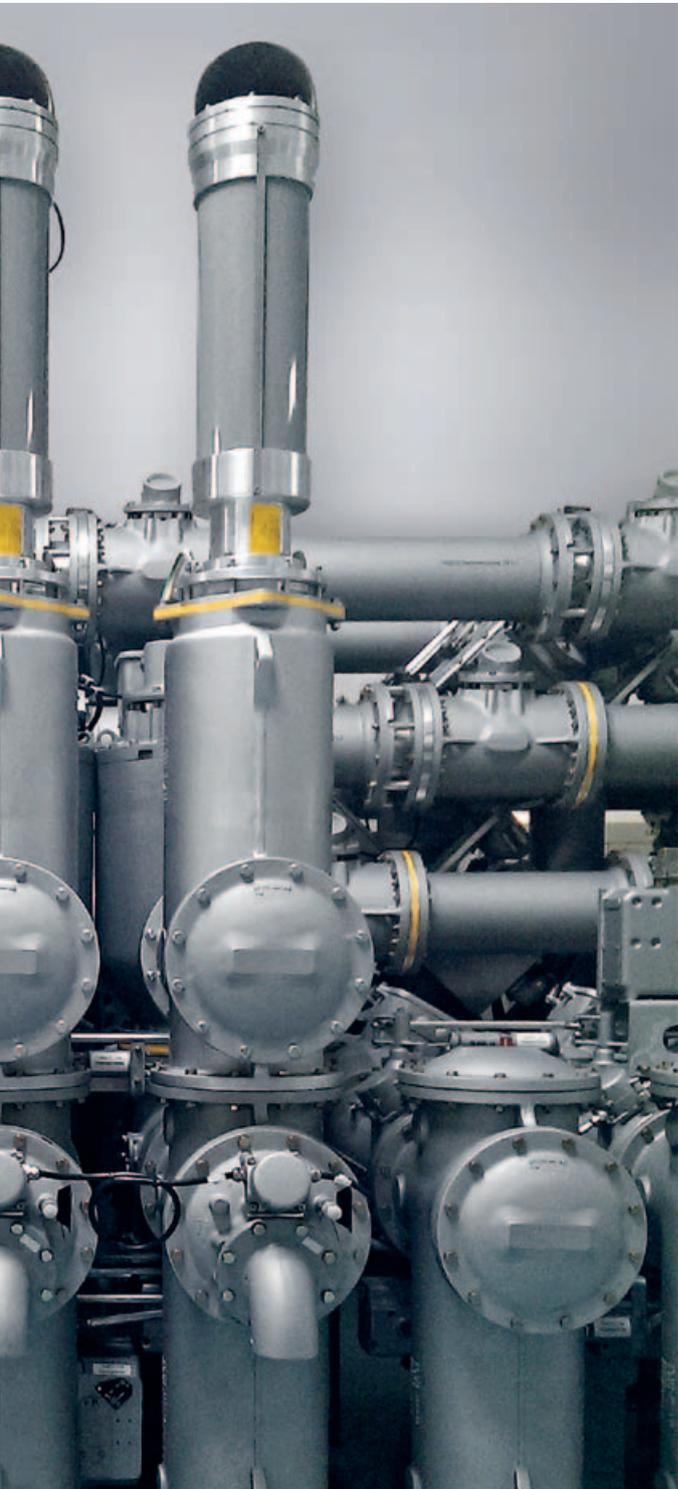

Ideal for GIS and transformers

The Klus substation replaced two old substations: the unit in Klus that was built in 1942 and the one in Balsthal in 1956. The planning and construction of the new Klus substation was the responsibility of Roland Büttler, working as Project Manager. Today he is General Manager, ensuring it operates smoothly. „Personal safety is one of the most important investment criteria,“ says Büttler, handing out helmets, safety shoes and jackets before beginning the tour of the substation on the ground floor.

«The best surge protection is achieved with arresters directly attached to the transformer.»

Roland Büttler, Project Manager for Primary Equipment at Alpiq and General Manager of the Klus substation.



Compact and pluggable, thanks to its solid insulation: HV-CONNEX surge arrester Size 4

In the first cell of the steel skeleton construction, he passed by the MV switchgear to the HV switchgear, pointing out the CONNEX components: “My experience is that CONNEX is the best way to achieve safety and reliability at the same time.”

What this looks like in practice becomes clear as the General Manager takes us through to the next cell. Here there is one of two 40 MVA transformers by SGB. Both are completely fitted with the CONNEX system. A total of 20 cable connectors connect the 16 kV and 50 kV lines to the transformers, flexible earthing options are available using removable dummy plugs on the MV equipment connectors, while four MV arresters and four HV arresters per transformer provide surge protection.

“The best surge protection is achieved with arresters directly attached to the transformer,” said Büttler, “That is why the introduction of HV-CONNEX surge arresters was very convenient. Because that meant we could make the transformers completely pluggable and safe to touch.” He ran his bare hand along the transformer before counting up the advantages of using CONNEX on his fingers. “Just as visitors can safely and easily walk through this plant, our maintenance staff can work here too. So we can clean the equipment, take oil samples and so on without requiring extensive safety precautions. On top of that, there is the ease of installation.”



Used throughout the Klus substation: CONNEX components for pluggable, touch-safe GIS in all situations.



Ideal for the interior: CONNEX surge arresters and cable connectors, Size 3 (left) and Size 4 (right) on the transformer

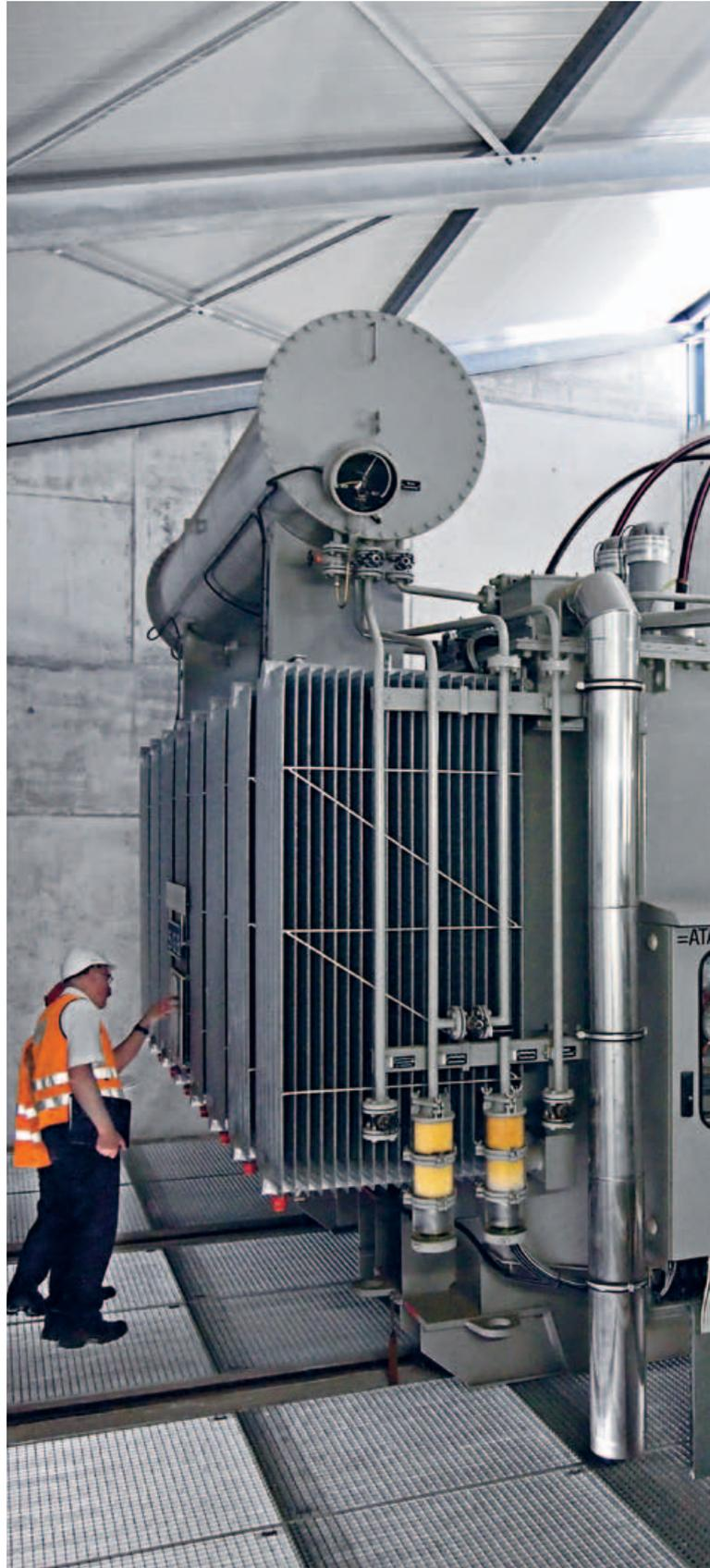

Safe and easy maintenance: Complete touch-safe power transformers at the Klus Substation thanks to using CONNEX



Economical in use

Standing in the concrete basement of the Klus substation, Büttler explained the cost advantages. “Can you see how the incoming and outgoing cables are laid out in here? Systematically and precisely. We are just as precise in calculating the costs of our plant. Using CONNEX certainly pays off. Thanks to the plug-in connectors, the initial installation was completed quickly without having to use technical specialists for oil or gas. If there were to be any damage, the standard components are easy to install and can be quickly changed over on the equipment, which in turn can also be used more flexibly.”

Büttler made exactly the same calculations when the Niedergösgen substation, 30 km away, was enlarged in 2010. Two solutions for extending the single-phase switchgear from Areva (now Alstom Grid) were under discussion—a conventional gas-insulated surge arrester or a Size 4 plug-HV-CONNEX surge arrester. The result: “The bottom line for this retrofit application was to combine the standard termination enclosure by the GIS system manufacturer with PFISTERER sockets and surge arresters, giving a much more affordable alternative.”

With CONNEX, all these benefits can also be achieved at even higher voltage levels. Such as Size 5-S surge arresters for up to 145 kV. In the next issue of CONNECT, we will report on a project that is a superb example of this.

«The bottom line for this retrofit application was to combine the standard termination enclosure by the GIS system manufacturer with PFISTERER sockets and surge arresters, giving a much more affordable alternative.»

Roland Büttler, Project Manager for Primary Equipment at Alpiq and General Manager of the Klus substation.

Unique earthing terminal. For HV cables with lead or corrugated metal sheathing

PFISTERER offers a so far unrivaled solution for the best possible earthing of high voltage cables with lead or corrugated sheathing – the new HV-CONNEX earthing terminal for cables with an external diameter of up to 210 mm. Successfully type tested. Easy to install and giving an excellent contact when in use.

There are many different type of high voltage cable available. In Europe there is the classic version using a copper wire screen, while a lead or corrugated sheathing is used worldwide. The first type are earthed by leading the copper wires out of the connector component and connecting to an earthing rail via a cable lug.

In the case of cables sheathed with lead or corrugated metal, the conventional earthing connection is more complex. Flat copper braids provide the connection between earth potential and the sheath. They are wrapped around the stepped cable, fixed to the casing with clamps and

hose clips and soldered to form a waterproof seal. Finally, heat shrink tubing is pulled over, which also gives protection against moisture and provides insulation.

Easily to install.

With the HV-CONNEX earthing terminal, things are easier. It consists of three clamping jaws, connected with threaded rods to the shear head and nut, forming the fastening system. When installing, the clamp is slipped over the stepped cable, screwed onto the cable screening and finally covered with shrink tubing. The connecting cable to the earthing rail is fixed to the terminal with a cable lug.

The benefit is that standard insulated earthing wire can be used to connect to the earthing rail. This eliminates the need for copper braids, and with them, the soldering. When screwing down the clamp, the shear heads break off once a pre-set torque has been reached. This is set to suit lead or corrugated metal sheathing according to customer requirements.

The ideal contact

This also ensures a reliable contact for the life of the component. Defined contact lines on the clamping jaws ensure perfect current transmission. The laminated disk springs integrated into the head nuts to introduce a degree of contact elasticity, so that the contact system can breathe thermally. Result: Although the operating temperatures may fluctuate, the contact force remains constant - over the entire lifespan of the component.

For Christian Späth, CONNEX Product Manager at PFISTERER, this is a key new development: "PFISTERER contact technology has proven itself in many different products worldwide. So it is only logical to use also the CONNEX system throughout, from high voltage contacts to earth connections."



For lead and corrugated sheathed cable: HV-CONNEX earthing terminals with line contacts and contact elasticity for long life and reliable contacts

SPPC 5 Phase Comparators: Superior in all situations.

The new SPPC 5 and SPPC 5 dual phase comparators from PFISTERER combine measurement accuracy with ease of use—thanks to their single-pole design, intelligent measurement technology and further benefits.

“Small measurements, big impact.” What Jürgen Finsinger, Product Manager for Safety Engineering at PFISTERER means is the effect on preventable incidents. An example: Two MV transformers were connected in parallel—out of phase as a result of a previous phase comparison. The result: the less powerful transformer exploded. “Although this is a very rare exception,” says Matthias Pirch, application technology expert at PFISTERER, “But it shows how important it is to carry out phase comparisons. In any situation.”

Two-pole phase comparators evaluate the voltage difference between the phases of two systems. A conventional method, which provides valid results. But one that is not always easy. Due to the resistive construction with a connecting line between two measurement poles, the measuring points of two systems must be simultaneously contacted in the test. Not only that. In practice, these are sometimes further apart than the user’s arm span and the length of the connecting cable.

Flexible. Precise. Robust.

In contrast, the capacitive construction of single pole SPPC-5 phase comparators makes it possible to scan the measuring points one by one. An integrated processor stores the respective phase differences and upon completion of the measurements superimposes these on each other and evaluates the frequency response independently of the time lag. Result? Precise measurements that can be reliably carried out in virtually any system configuration.

Furthermore, the newcomer offers the benefits that are already well known in the voltage testers from the KP-Test 5 series. Powerful perfectly positioned LEDs provide a clear view of the test results. When out of phase, they light up in red, accompanied by a distinctive audible warning signal. They can be used in rain and at temperatures from -25°C to 70°C . Further benefits with the dual version are that the main voltage levels are grouped so that only one switching circuit is required. The selected voltage level is clearly displayed during the measurement. The two phase comparators are available for the medium voltage range from 3 to 36 kV.

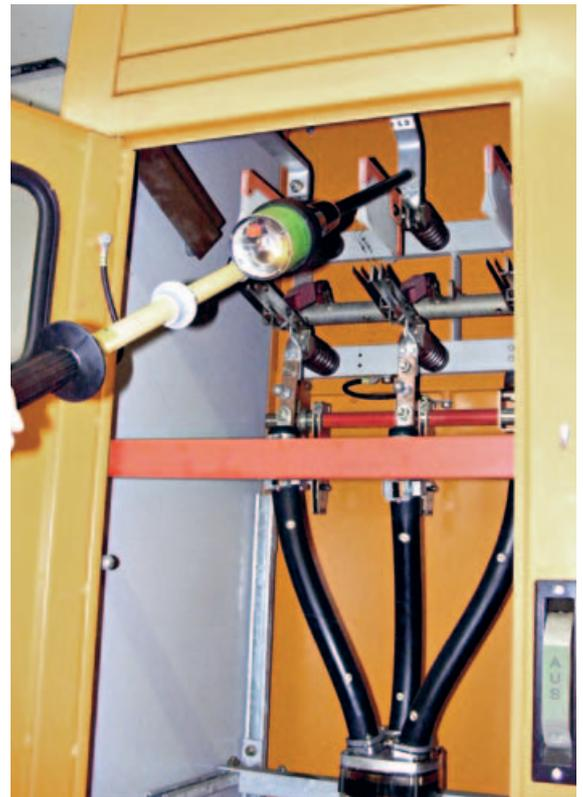

Prevents accidents: Check the phases before connecting up components.

100 percent glass cap insulators. That was the situation in Denmark's high-voltage systems—until 2012, when ENERGINET, the state energy company, began building a new transmission line. With the goal of constructing it using state of the art technology, seen from the population's point of view, they awarded the contract to the Bystrup architectural and design office and PFISTERER. Result: aesthetically attractive pylons, equipped with advanced composite insulator strings.

The new 400-kV transmission line will play a key role in the country's power network. The new Danish government is aiming for wind energy to have a 50% share by 2020; in 2011 wind turbines were already generating 28.1 % of Denmark's electricity. In order to ensure that power flows reliably even when there is no wind or can be used efficiently when there is an excess, the new line makes it possible to import and export electricity, with connections to Norway, Sweden, Germany and possibly the Netherlands.

The new line will replace an existing one and with a total length of 183 km will extend from Kasso to Tjele—about half of the north-south axis of the country. To increase its acceptability to the population, ENERGINET put great emphasis on the aesthetic appearance of the towers. Bystrup, the Danish architecture and design office, supplied the designs. In 2011, Bystrup had excelled with their "T-pylon" design for future towers in the UK power grid.

Good looking. Strong. Silicone insulator.

The visual standards laid down by Bystrup together with the functional demands made by ENERGINET led to complex requirements for the insulator strings. They had to be harmoniously integrated into the tower design whilst at the same time withstanding high mechanical loads. Year-round high winds and heavy snow in the winter places strains on transmission lines, towers and the insulator strings connecting them. The technical implementation of these requirements ruled out the use of conventional insulators in the V-chains, as in this application they are under compression



For ultra-modern overhead lines with an aesthetic design, PFISTERER supplies application-specific complete solutions from a single source.

Pioneering HV Pylons. With insulator strings from PFISTERER

Glass cap insulators, however, can only take tensile loads. However, porcelain rod insulators can only be produced with a limited maximum length, which restricts their use. To achieve the required values, three to four porcelain rod insulators would need to be installed per connection in series, with additional protective fittings - which would not meet the “unobtrusive appearance” requirement.

With PFISTERER’s silicone rod composite insulators, things are different. In order to achieve insulator lengths of up to 7m, the company developed the ACIM (Automatic Continuous Injection Molding) method. This enabled them to pro-

duce composite insulators for this project that were around 4 m long. Just one of them performs as well as several porcelain rod insulators—and with the aesthetic appearance required.

Close to the customer

“These benefits were very persuasive for ENERGINET, as were our many years of expertise in developing customized chain solutions,” says Reto Achermann, Project Sales Manager at PFISTERER, “So the power company also decided to specify our suspension and tension string sets for a complete solution with composite insulators. Here the tension string sets were specified to be able to withstand exceptional tensile loads of up to 1,000 kN, including the safety factor.” Additionally, PFISTERER supplied field spacers and Stockbridge dampers. They proved themselves in use, as demonstrated by cable vibration measurements over three winter months.

ENERGINET gained confidence in both the products and the company during the course of the prototype tests, carried out at PFISTERER’s Swiss location in Malters. “An insulator string is more than the sum of its parts,” explains Sergio Thaddey, Project Manager Engineering at PFISTERER, “The key is the interaction between the insulator and attachment fitting. This we evaluate using computer simulations, based on project-specific models.” And how is the cooperation between ENERGINET and PFISTERER?

Very good as far as Bjarke Jensen, Project Manager at ENERGINET, is concerned: “Expert advice, short chains of command, flexible design, a good start all round—and with potential. And that includes the possibility of using PFISTERER solutions in a future project.”

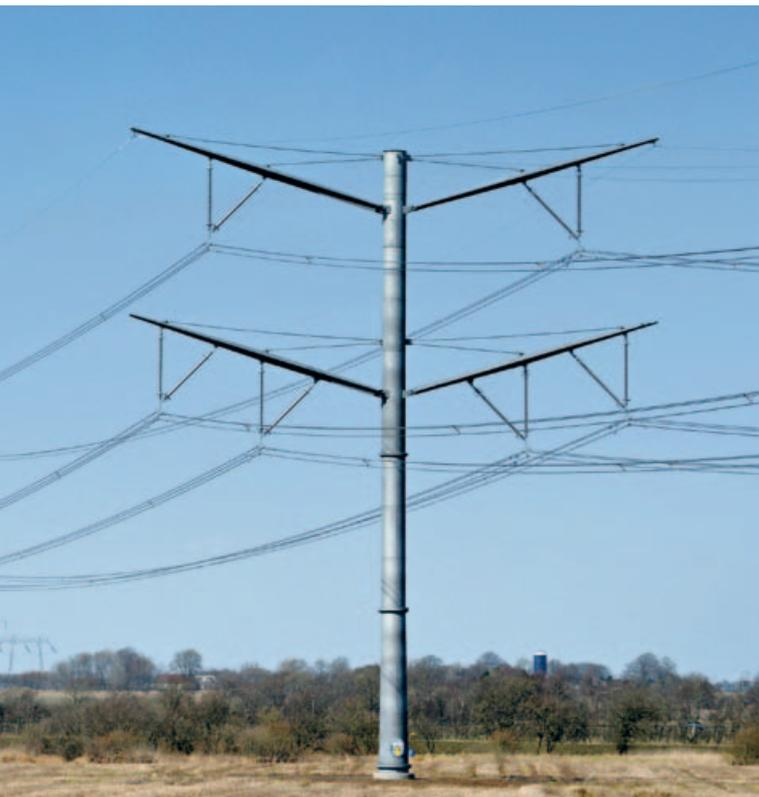

Source: Bystrup



Only achievable with silicone rod composite insulators:
Compact and pressure-resistant V-chains



Extensively tested insulator strings ensure a smooth installation and ongoing reliable operation.

Termination installation – faster than ever. Thanks to EST.

Chosen as the innovation at the Amper Fair in 2012, confirmed as a step forward by experienced practitioners in 2013: In June, the EST 123 dry termination was installed in Austria for the first time in the distribution network belonging to Netz Burgenland by Energie- und Telecom Netze GmbH (ETN). The ETN specialists' conclusion? The EST sets new standards in terms of user-friendliness.

The words and actions of the ETN professionals carry weight. Industrial and electrical contractors also rely on their expertise. These include the large players in the Austrian energy sector, including Netz Burgenland, the electricity distributor in the Burgenland region. To ensure an ongoing high level of security of supply, the company invests around 31 million euros in the renovation and maintenance of the power grid every year.

One of the many projects was the laying of a bypass line between two 110-kV lattice towers, located at the Parndorf wind farm. The towers belong to two different transmission systems. If an incident were to occur in one of the systems, current can flow through the bypass to the other system that is still functioning and the supply remains secure throughout the entire process.

1 Termination – 2 Benefits

The bypass was designed as a 110 kV cable line. It was connected to one of the two lattice towers using three PFISTERER terminations, type EST 123-C31L. The EST is designed for continuous operation at voltage levels from 72.5 to 170 kV and consists of a flexible ESF and an additional support element. Thanks to the use of silicone insulation, both EST and ESF work without any oil at all.

The PFISTERER terminations are not only environmentally friendly, but also easy to install. The silicone bodies are made of modular components that can be easily fitted together and glued. This means that the EST can be installed on a tower without scaffolding. The termination is already connected to the high voltage cable on the ground, and then the cable is pulled up. Compared to conventional connectors, they quickly save several thousand euros in installation costs, with the downtime on the overhead line reduced from weeks to days.

Installed in 4 days

That was the experience of the ETN installation crew. Installing the three ESTs required only four days, despite difficult conditions. "The tower could only be partially insulated for installing the termination. One of the two systems was always at operating voltage," says ETN installation manager Peter Grubits, "Thanks to EST, we could make up for the extra work resulting from this." He and his staff completed the pre-assembly of the terminations in containers, which were watertight and clean.

Josef Kuktits, General Manager at ETN concluded: "We have been using PFISTERER products for many years. The EST is another example of how the company develops its innovations with a view to using them in the field." For Peter Feldhofer, CEO at the PFISTERER subsidiary in Vienna, the project represents another positive milestone in the company's long-term cooperation with ETN: "Our experience is that if ETN is involved in an installation, we can expect to see high quality work. That is something that as partners we can also claim for our products."



Ready for quick installation on the tower:
EST terminations after pre-assembly in a weatherproof container



Installing on the tower at unrivaled speed: EST terminations can be pre-assembled on the ground—without time consuming work with oil.



More information is available
on www.pfisterer.com

HV-CONNEX: Advances for transformers. Fit for esters.

There are many insulating fluids for transformers. Esters are currently considered to be the most advanced—thanks to their environmental friendliness. The HV-CONNEX connector system is equally reliable in use with both conventional and modern insulation media. It has proven its value in mineral oils, both in standard tests and in practical use. And it has now been confirmed with type tests in synthetic esters, carried out according to IEC 60137.

Anyone who has looked closely at the ranges offered by both large and small transformer manufacturers will have discovered that more and more transformer designs use natural and synthetic esters as an insulating medium. Synthetic esters have been used for over 25 years as an alternative to mineral oils. If they had not proved their functional capability over this period, no transformer manufacturer would be using them any longer. Because inside the transformer, they have to do more than simply be non-toxic, readily biodegradable and non-hazardous to water.

“Transformers are integral parts of power grids, costly and not immediately easily accessible,” says Andreas Dobler, Sales Manager for Cable Systems / Application Engineering for Transformers and GIS at PFISTERER, “None of this is new, but is something which everyone who produces or uses transformers is concerned about.



Source: Shutterstock

Furthermore there are complex issues arising from the nature of the systems engineering and the application – even with insulating liquids”.

Withstanding water and heat

Whether modern esters or conventional oils, they must perform the same tasks in the transformer - cooling the windings and insulating high voltages, reliably and over several decades. For this, they must have certain properties. One of several is the need for high water solubility. Because water causes the insulation to age more rapidly. However, it is not possible to completely get rid of water from any transformer, or not so far, anyway - not even from a hermetic transformer. Because water is always the largest component in the solid insulation, and no transformer can function without that.

Another important property is thermal resistance. The higher the thermal resistance, the longer the insulation system lasts, because it can better withstand high operating temperatures. And more compact transformers can be built. This saves valuable installation space, such as on offshore platforms and in underground power stations. It also makes it easier for railway businesses to keep within defined maximum sizes in rail transport.

Esters: Benefits & Challenges

There is no dispute, oil-based insulating fluids achieve these properties. But scientific studies also show that in many ways esters compare favorably. One example is that they have a higher flash point – an important aspect in locations which are subject to increased fire safety regulations. At the same time, these studies emphasize that the specific characteristics of esters must be taken into account when using them. PFISTERER is aware of this.

“Every insulating medium has different dielectric insulation properties. Therefore, depending on the medium, other field conditions dominate in the vicinity of transformer components,” explained Dobler, “When used in synthetic esters, the field strengths are higher in parts of the solid insulation, while in other areas they are reduced. That’s why we asked ourselves the question: How do our HV-CONNEX sockets perform here? We wanted to find a valid answer.”

PFISTERER can now give one. With positive results. That is thanks to the success achieved in passing type tests in accordance with IEC 60137, conducted by the independent Karlsruhe Institute of Technology (KIT), also known as the Institute of Electrical Power Systems and High Voltage Technology (IEH). All sizes of sockets in the HV-CONNEX system were tested in synthetic esters, each with cable plug, some with dummy plugs or pluggable bushings as well, in each case without making any changes to the components to suit the increased requirements. Ergo: HVCONNEX was a resilient component before the trend to esters started.

«Every insulating medium has different dielectric insulation properties. Therefore, depending on the medium, other field conditions dominate in the vicinity of transformer components.»

Andreas Dobler, Sales Manager for Cable Systems / Application Engineering for Transformers and GIS at PFISTERER.



Universally applicable: All components in the CONNEX system can also be operated in transformers with esters as an insulating medium.

This part of the practical CONNECT series of reports on the fundamentals of contact technology provides an overview of traditional joining techniques—compression, plug-ins and screws. It shows that advanced terminals can withstand far more than natural contact aging. They make installation is easier, reduce the risk of faults, offer higher safety and cover a wider range of applications.

If one looks at the history of contact technology up until the present time, it opens up a wide field. It covers all mechanical connections of conductors in electric power networks, or more precisely, cables and overhead lines. Worldwide, three connection techniques have been used until now. Compression, plug-ins and screws. All three can be used

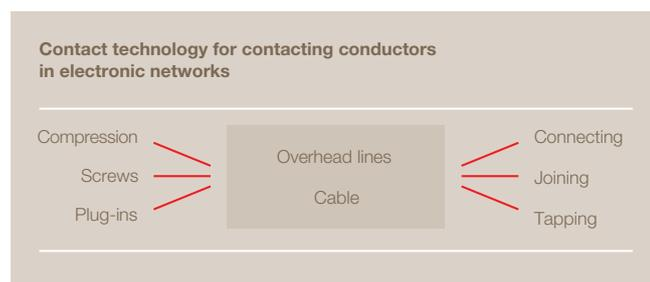

Figure 1: Overview of the broad field of contact technology today—starting with the three main techniques to conductor types and the three common basic types of connection.

with different weightings for the three basic forms of contacting—tapping, joining and connecting (Fig. 1). In contrast, the traditional welding and soldering techniques used some years ago are as good as gone.

Compressing to measure

The principle of compression technology is based on the radial and axial deformation of the sleeve and the conductor ends inside it, using compaction. There are two basic ways to achieve this. Shape-controlled symmetrical compression (for example, round or hexagonal compression, Figure 2) and force-controlled asymmetric compression (for example, deep groove compression). The latter is not approved for contacting overhead lines, since in this case the individual wires are compressed more strongly and as a result flow away in a longitudinal direction (axial deformation). This causes the conductor to become thinner at the contact point (loss of cross sectional area) and its mechanical strength decreases. Overhead lines, however, are increasingly exposed to various tensile forces, such as their own weight and vibrations due to wind and weather, and thus must have a particular tensile strength.

Contact technology manufacturers take account of these tensile forces in all techniques - especially in compression technology—as they face the challenge of bringing two opposing processes together. On the one hand, the higher the contact force, the more the resistance the current has to overcome disappears—a sought-after effect. Because at higher resistances, the thermal load on the contact increases, accelerating its aging (for details see CONNECT 1/2012). On the other hand, when more than a certain force is applied during contacting, the conductors are deformed too much. If their mechanical strength is too low, they break when under higher tensile forces. The solution is to select the contact force such that the connector is equally suited to the electrical and mechanical requirements (Fig. 3).

From proven contacting techniques to innovative connectors

Plug-in technology for removable contacts

Practice proves that this can be achieved. Compression technology took its place alongside screw technology in Europe in the 1960s and is now used worldwide, primarily for connecting and joining conductors with cross sections from 16 to 2500 mm². Compression technology and the more recent plug-in technology share the same important discovery that several small defined contact points produce a higher quality contact than a single large contact area (detailed info 1). These methods were increasingly used in the 1970s and 1980s, as cable was being used to an increasing degree and there was a rising demand for touch-safe connections. This required fully enclosed contact systems that could be disconnected and reconnected again.

The dry plug-in and touch-safe CONNEX cable connection system provides a more advanced solution to this problem. A plug is fitted to the end of the cable to be connected, which in turn is plugged into a socket built into the equipment. These days, all kinds of connectors are used, mainly to connect, followed by jointing. A few products also making tapping possible—which is less frequently required—using plug-in technology, such as T-junction joints. The principle of elastic line contacting is also applied when developing and designing connectors, (Fig. 4).



Figure 2: A reliable and durable contact requires an optimal transverse conductivity in the conductor. For this purpose, when using the compression technique not only should the outer layers of the stranded conductor be compressed, but the inner layers as well. This picture shows the ideal compression using a symmetrical compression method: All of the individual wires can be seen to have the characteristic angular deformation.



Figure 4: As a service life of several decades is required, during the design of the connectors the contact points are defined as contact lines and a high degree of elasticity introduced by using springs.

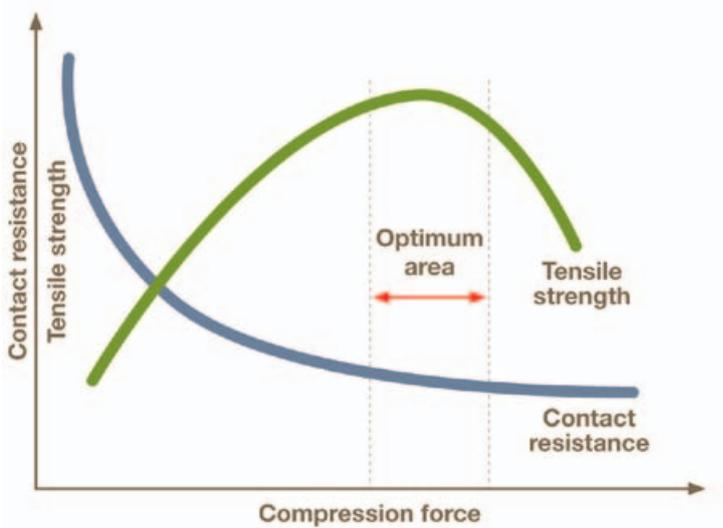

Figure 3: The design criteria used in compression technology matches electrical and mechanical requirements to one another. During compression, a contact force must be selected so as to reduce the contact resistance and simultaneously maintain the maximum possible tensile strength of the connection.

Screw technology: Past & Present

The oldest contacting method uses screws with a variety of different terminals (Fig. 5) for connecting, jointing and tapping. Here we need to differentiate between two basic approaches. The older, that comes from overhead line technology, involves bare screws while with the younger one, insulated screws are used. The requirements for bare overhead line terminals are sometimes lower because overhead lines are surrounded by air and are cooled by the

wind. This contrasts with insulated cables that are mainly laid underground, and where the insulation retains the heat. This why the insulated cable clamps used in such situations must not age prematurely due to the temperature (CONNECT 1 /2012) and certainly not overheat. They must therefore meet higher standards as regards contact technology. For all screw connectors, contact force is created by screws (for design rules for screw sizing, see CONNECT 1 /2013)

As in compression and plug-in technology, contact technology equipment manufacturers are also trying to transfer their basic knowledge and practical experience to advanced terminal designs. With some success. The use of innovative screw terminals, such as the ISICOMPACT, simplifies installation and improves safety in the workplace at the same time. They are more economical to produce, while their ability to be used in a number of areas means that the application possibilities are multiplying. The following features characterize such screwed connections: an insulated and therefore touch-safe design thanks to the body being made of plastic and the use of insulation-piercing contact elements (CONNECT 1/2013) and also single-screw technology with torque release.



Figure 5: Screw technology is not only the oldest type of contact technology, with a wide variety of connector types, but also provides the most advanced terminals in use today.

Detailed Information 1:

Experiments have shown that more defined contact points are better than a single large contact area. The application of this knowledge is used, for example, in compression technology by way of multiple compression. Wherever the edges of the compression tool press into the sleeve and conductor, other edges will form. These act as a contact lines through which the current flows in a defined way from one conductor to another. Not only that. The compression force causes the conductor to spread out, so that it extends lengthwise and is compressed into the spaces between the individual compression points. The elasticity is stored in these bunched up areas. Under various thermal conditions, this always causes the fixed conductor to be pressed into the compression edges—the contact lines—with a certain force. Thus the required minimum contact force is maintained over the entire lifetime of the connection.



Another example here is the SICON connection concept. The impetus for its development came from changing market demands: Over the last thirty years, the number of cable types and cross sections have multiplied, while the profile of a fitter has changed from being a specialist to being an all-rounder. In addition, the development of flexible plastics brought joints to the market that could be used for a variety of purposes. The resulting need for versatile connectors that can be easily and safely installed meant that the current solutions were not good enough. Compression technology was inherently unsuitable, as the relationship between cross section of the conductor and the cross section of the sleeve and tool was fixed and thus required not only a wide range of material and tools, but also specially trained personnel. The principle of modern screw technology also offers the potential to meet today's demands, whilst at the same time conventional screw connections are failing to do so because of their weaknesses.

New technology, new challenges

Here is one of them: Achieving the optimum contact force is not guaranteed because the process depends on two uncertain factors. One is the installer's subjective assessment as to if and when sufficient force has been introduced. Another is that the torque wrenches used to remedy this are not always as reliable as needed. Another disadvantage is that the screws protruding through the connector body make it harder to fit the sleeve. The first attempt at optimization was to use multi-stage shear bolts. As the name implies, they snap off when the contact is made, making it easier to fit the sleeve. Snapping occurs at defined breaking points when a predetermined torque is reached.

However, this innovation has its limits. There is a prevailing requirement in the market for just one connector that can be used with cross-sections ranging from 50 to 240 mm². This covers the seven cross-sections, 50, 70, 95, 120, 150, 185 and 240 mm² and thus seven different nominal diameters. However, the multi-stage shear bolts have a maximum of three breaking points, so a minimum of four cross-sections are not accurately covered. On the other hand, it is not feasible to have seven breaking points on a screw because every breaking point weakens the thread.

The greatest disadvantage of multi-stage shear bolts is that they can technically only be produced in the form required so that they snap at their first breaking point near the conductor at the lowest defined torque and also at the last breaking point nearest the screw head at the highest defined torque (Figure 6). The result is that when you have to tighten the screw all the way—i.e. when joining the smallest possible conductor sizes—the largest torque must be applied, and vice versa. This means the smallest conductor experiences the highest contact force while the largest has the smallest contact force.

Not only that. Basically, it is always the case that only a part of the applied torque is translated into contact force. The other part is converted into frictional forces. One of these is the inevitable thread friction. As a natural counterforce to the contact force, this increases or decreases in proportion to it, and is therefore manageable even with conventional connectors. Unlike in the case of head friction. With traditional screwed connectors, this works between the screw head and the surface, and is therefore highly variable, depending in this situation on the conductor material, conductor hardness and the condition of the conductor surface.

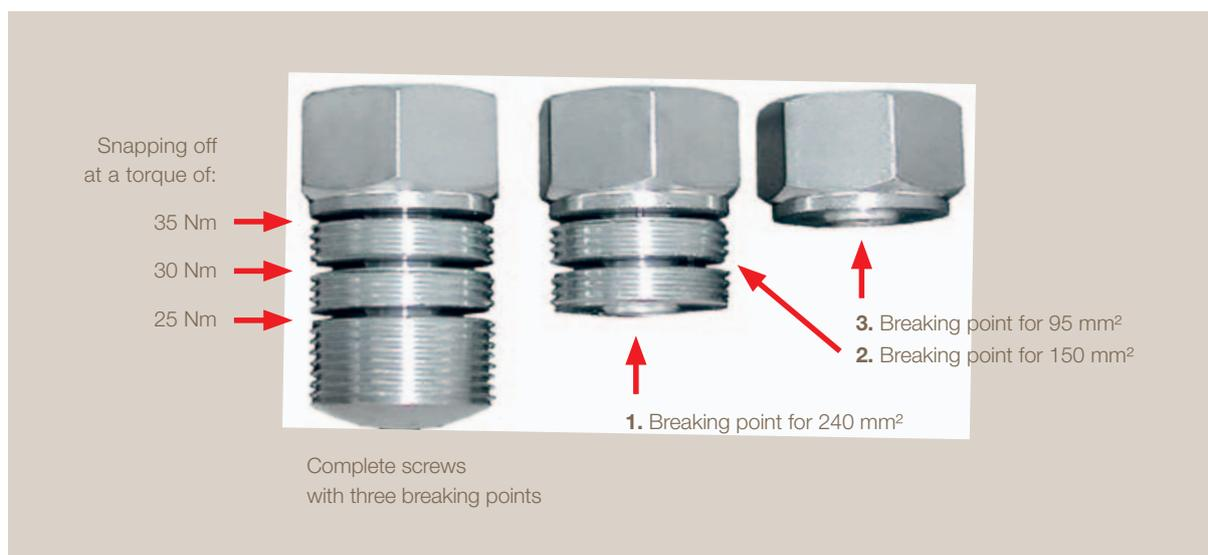
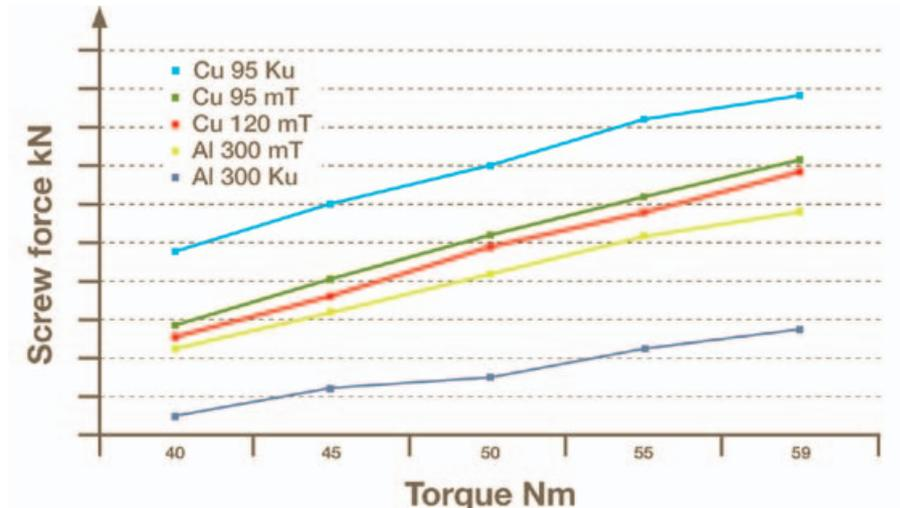

Figure 6: Disadvantage of shear bolts with multiple stepped breaking points: The largest defined torque (35 Nm) must be designed to work on the third breaking point, while the smallest defined torque (25 Nm) must work on the first breaking point. Because of the torque-controlled force, the smallest conductor (up to 95 mm²) experiences a greater contact force, while the largest conductor (up to 240 mm²) is contacted with a lower contact force.



Thus the head friction is very high when using a standard connector on aluminum conductors, and there is a risk that insufficient contact pressure will be applied. The converse is true if the same connector meets a copper conductor. The head friction is then significantly lower, but in this case the risk is that too much contact force is applied, the thread breaks or individual wires are damaged. Here we have not even considered other important factors, namely the conductor hardness and conductor surface.

Advantages of modern screw connectors

The bottom line is that one conventional connector alone cannot be effective with a wide range of conductors. To make matters worse, with multi-stage shear bolts the adverse relationship of torque to breaking point cannot be reversed, due to their construction. Overall a fatal outcome, as the central factor—contact force—cannot be reliably defined for each connector by the means shown.

Compare this with SICON, the latest development in the field of screw connectors. The two most important new features of the patented connection system for cross sections from 25 to 2500 mm²: The stepless version of the shear bolt as well as the integrated pressure washer on the end of the screw. Both combine together to provide optimum contact force with a wide range of conductors, regardless of their nature (detailed info 2). Even Class 5 stranded fine wire conductors can be contacted without damage. How exactly this happens is explained in Detailed Info 3 For the development of these important functional elements, the forces and stresses acting within the connector must be brought under control. The finite element method (FEM) was used to calculate and visualize them, together with the analysis of single screw connector functions (Fig. 7).

In the meantime SICON has proved itself in practice at all voltage levels. The connector system meets current market requirements (use in different areas, easy installation, higher installation quality) and takes into account basic knowledge (CONNECT 1/2012 and 1/2013). In the SICON design, the latter is illustrated as follows: A thread introduced into the wire path, generating defined contact lines.

Detailed Information 2:

In the case of screw connectors with integrated pressure plates, the head friction operates between the pressure washer and the screw, i.e. between functional elements, whose condition is determined by the manufacturer of the screw connector. The head friction is thus almost independent of the conductor, can be calculated by the manufacturer and included in determining the appropriate torques. Result: A screw connector with a pressure plate (mT) can create the required contact force, even with conductors that have very different coefficients of friction, such as conductors of copper and aluminum (middle three lines). It is different with screw connectors with screw tops (Ku), which have a ball headed screw end: Here, the head friction acts between screw and conductor, and is therefore dependent on the conductor material, hardness and surface—all varying factors that are beyond the control of the manufacturer. As a result, depending on the conductor, the applied torque is more or less converted into contact force (top and bottom line) and the creation of the optimum contact force is not guaranteed.

Tinning the entire connector body and greasing the conductor conduit during production protects the contact from oxidation and ensures its long-term durability. Design flexibility is achieved by material selection as well as the defined ratio of conductor diameter to the wall thickness of the connector body. When the screw is tightened, the connector body is permanently elastically deformed so that it acts like a preloaded spring. This counteracts the settling and flow processes while at the same allowing the system components to breathe thermally. All of these features keep the natural contact aging at bay.

How long does the contact last?

How long the contact will actually last is a question that arises with all types of connector. However, with a service life goal of four to five decades, real-time testing is impractical. This why during the type testing of new developments, aging tests are carried out using an accelerated process.

At least they allow a statement to be made as to whether a connector is in principle capable of reliably and continuously fulfilling its role in the energy grid. On-site inspections, however, are used to predict the remaining lifetime of connectors already in use. Bearing in mind the experiences of recent years, this raises another question: Are there reliable methods of doing this?

The answers will form the last part of this series of reports, focusing on type testing and on-site inspections. This can be found in our special publication in which all reports are summarized. It is readily available as follows. Download as a PDF document using the following QR code or from our website, www.pfisterer.com. Or the printed edition from our PFISTERER sales staff.

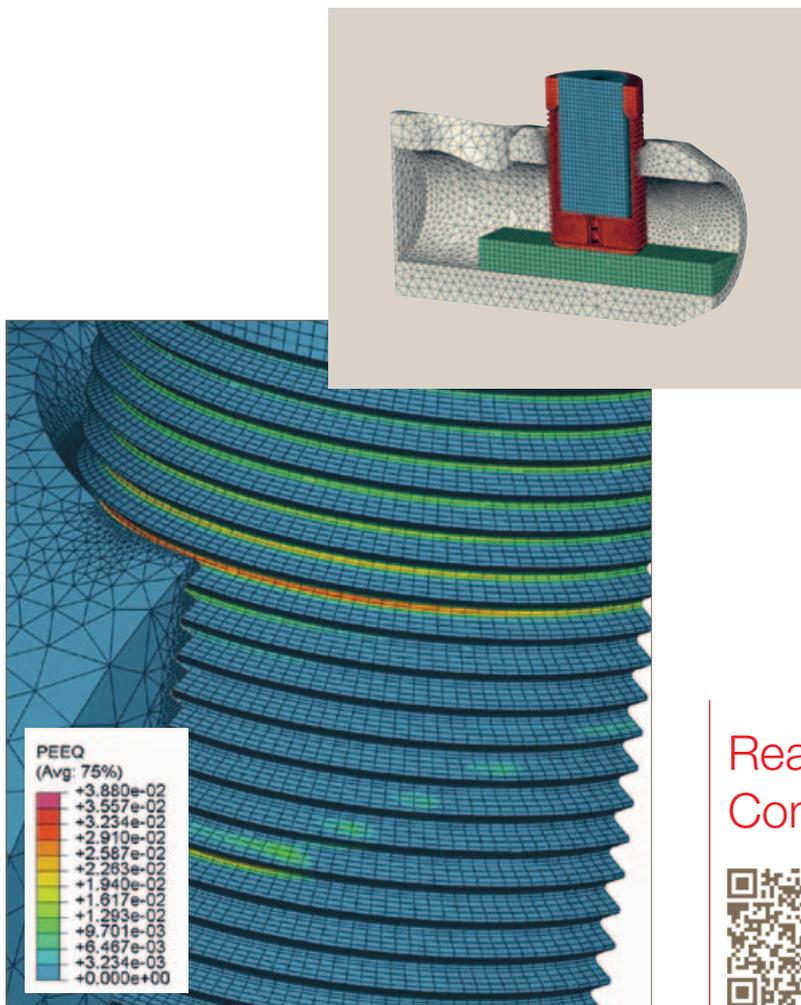
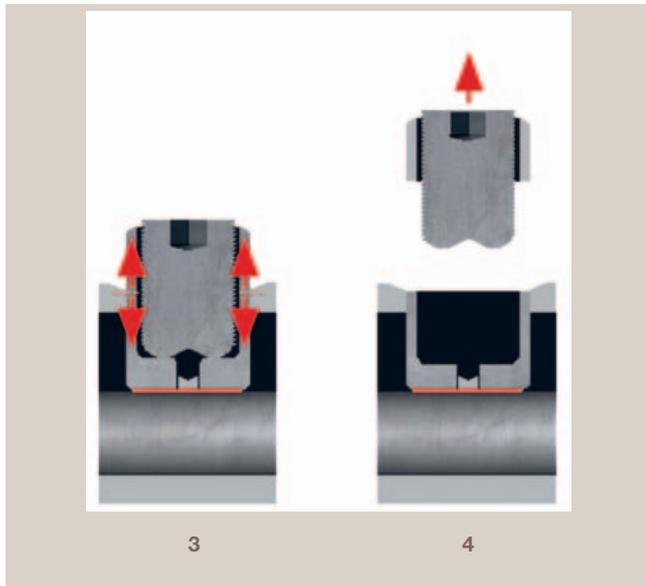
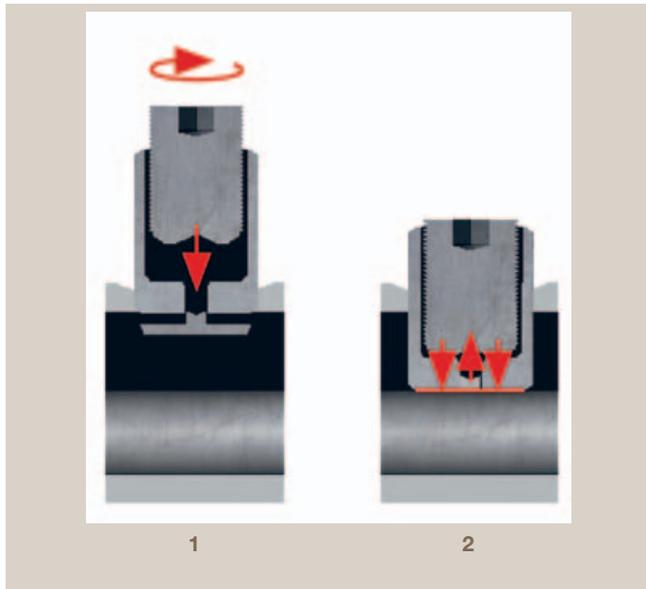

Figure 7: The upper FEM simulation shows what forces and stresses are acting on a SICON screw connector. The lower FEM analysis shows the operation of its stepless shear-head system. The first free thread on the SICON screw where it exits from the thread in the connector body is also an area subject to the highest mechanical stress. Summary: The stepless bolt will break off automatically at this point when the optimum contact force is reached - with no breaking points.

Ready for you:
Compact knowledge



We have put together the complete series of reports for you in our current special edition, covering the basics of contact technology. You can download it as a PDF document using this QR code or from our website www.pfisterer.com. Our sales staff will send you the print edition on request.



Detailed Information 3: The SICON screw principle

1. The SICON screw consists of a screw, a threaded sleeve with internal and external threads and a pressure plate on the end of the screw. Thanks to the stepless screw design, the buildup of the contact force is not interrupted by steps or notches on the screw. When screwing in the SICON screw with a standard hex wrench, the screw turns in the threaded sleeve until it reaches the bottom of the sleeve.

2. The threaded sleeve now rotates as well, the pressure plate at the end of the screw meets the conductor that is to be connected. The pressure plate is released from the bottom of the screw, the screw continues to rotate on the plate. The plate remains solidly locked on the conductor surface, since the friction between the washer and conductor is much higher than the friction between the washer and screw. Advantage: On the conductor itself no more head friction occurs, the torque of the screw is converted into contact pressure virtually independently of the conductor (detailed info 2). This presses the conductor to the opposite wall of the connector body, thus establishing the clamped connection. At the same time the pressure plate protects the conductor from damage caused by the contacting process.

3. The SICON screw rotates until the shear torque is reached. Here, the interplay of tension and contact force comes into play. Both are caused by the screw being turned in, each being equal and opposite forces according to the mechanical law "force equals opposing force": The contact force is applied to the conductor, the tensile stress is in the opposite direction onto the threaded sleeve of the SICON screw. Once the optimum contact force associated with tensile stress is established, the shear torque is reached – the screw under tension is stretched axially within a predefined range of the screw sleeve, until it shears off.

4. The SICON connector is constructed such that the point of maximum tensile stress is always located where the threaded sleeve emerges from the connector body. Thus, seen from the outside, at the same time the first free thread forms the shear edge (Fig. 7). Ergo: The SICON screw will always break below the surface of the clamp body and this without any sharp edged protrusions on the screw. This eliminates both the need for filing, as was previously required, and the risk of a shock due to metal swarf. Compared to conventional shear bolts, the SICON screw shears gently and almost without a jerk.

News



HV-CONNEX: Size 5-S with new tension ring

For even easier installation, PFISTERER has adapted the Size 5-S HV-CONNEX socket to have the advantages of Size 6. Result: a new socket design with a slim tension ring that can be freely rotated and thus can be aligned to the orientation of the device's contact hole pattern. The fixing hole, the device's contact hole pattern and the standard dimensions are all maintained. Both optimized and previous Size 5-S sockets can be replaced without modifications. The Size 5-S cable connector also remains unchanged and can be used on both socket versions. There is no need for any changes to switchgear or transformers designs.



Practical Tip PLUG-assembly as a clip

The ease of assembly of the powerful compact PLUG connection systems already speaks for the quality of their design. Coded and modular, they cannot be mixed up and are easy to install. PFISTERER demonstrate that they perform as well as the claims in a demo movie on their website. The clip shows, step by step, a PLUG installation, here a Size 3, 6.6 kV angle plug. From the correct positioning of the cable through to the fitting of the contact part, silicone seal and housing, to screwing onto the equipment, and including tips for protecting the conductor and the use of tools. Installation is quick. In the film, it takes barely four minutes and not much longer in real life. PFISTERER supplies the appropriate installation instructions with each PLUG.

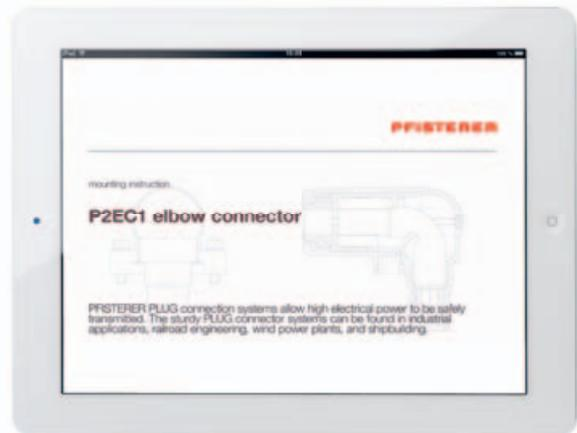

More information is available
on www.pfisterer.com



Compact. Pluggable. HV-CONNEX surge arresters



- Solid insulated
- Compact design
- Can be changed without gas or oil work on the GIS or transformer
- Size 4 up to 72.5 kV
interchangeable with all pluggable components in the Size 4 HV-CONNEX system
- Size 5-S up to 145 kV
interchangeable with all pluggable components in the Size 5-S HV-CONNEX system